

S3210P

PUSH-AROUND MINI SCISSOR LIFT



- Outdoor-rated
- Simple to use; easy to maintain
- No stabilizers required
- Durable design for tough site conditions
- Proven benefits over other low level access products

 **snorkel**[™]
www.snorkellifts.com

PUSH-AROUND MINI SCISSOR LIFT

S3210P

DIMENSIONS	S3210P*
Max. working height	5.0m
Max. platform height (A)	3.0m
Platform size (outside)	1.1m x 0.52m
Overall width (B)	0.81m
Overall length (C)	1.2m
Stowed height (D)	1.8m

PERFORMANCE	
Platform capacity (SWL)	240kg
Max. wind speed	12.5m/s
Raise/lower time	19/26 sec

POWER	
Power source	12V DC battery
Battery charger	Built in multi-voltage (90V - 240V)

WEIGHT	
Weight	470kg

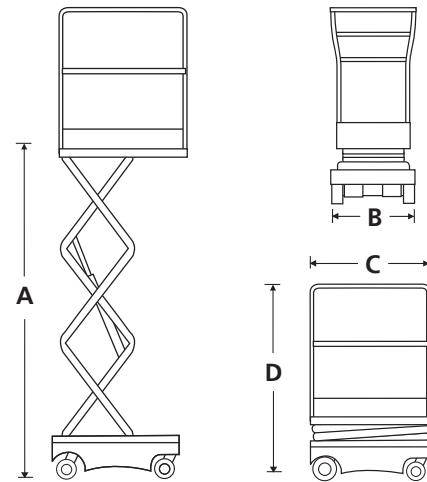

STANDARD FEATURES

- Outdoor-rated
- Auto brake system
- Tilt sensor
- Saloon-door style entry gates
- Integrated battery charger 90V - 240V
- Battery charge indicator
- Forklift pockets
- Emergency lowering system
- Non-marking casters
- Slide-out service trays
- 2 year parts & labor, 5 year structural warranty
- ANSI compliant

OPTIONS

- Special paint colors
- Environmental hydraulic oil
- Snorkel OnSite™ telematics

PLATFORM HEIGHT

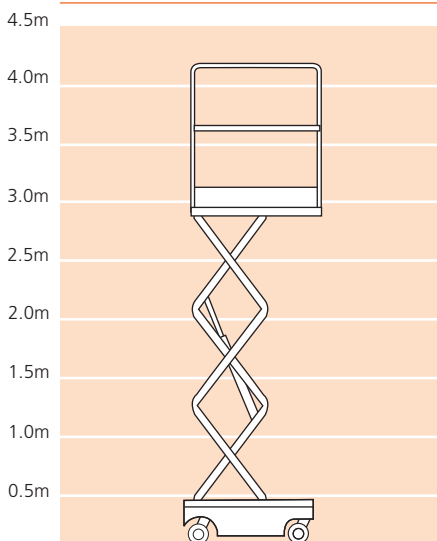

S3210P



P.O. Box 1160
St. Joseph, MO 64502-1160, USA
Tel: 1 (785) 989-3000
Toll-free: 1 (800) 255-0317
Fax: 1 (785) 989-3070
Email: sales.usa@snorkellifts.com

www.snorkellifts.com