



WPT45

Walkie Pallet Truck

LOW COST MOTORIZED PALLET TRUCK, IDEAL FOR CROWDED LOADING DOCKS, WORK CELLS AND CONGESTED AISLES.

CAPACITY

4500 lbs.

BATTERY

Compartment: 26.37" x 9.1" x open. Anderson 175 Gray—A-11 Minimum battery weight 175 lbs.

SPEED

Variable 0 mph up to 3.5 mph empty
Variable 0 mph up to 3.4 mph loaded

WEIGHT

670 lbs. Chassis Only

TIRES

DRIVE

9" x 3" polyurethane

LOAD

3.25" x 4.5" polyurethane

TILLER ARM CONTROLS

Travel, lift, and lower functions are located in the ergonomic operator handle. All operator controls are accessible without having to lift the hand from the handle.

Angle grips are designed to allow easy operation with either hand. Wrap around guard, reversing switch, thumb control, and horn are standard. Low mounted tiller arm offers excellent operator comfort and minimum steering effort. Gas assisted spring handle gently returns handle to vertical position.

Crawl speed function with steer handle at 5° back-tilt from vertical allows for ease of use in tight areas.

ELECTRICAL

24-Volt ZAPI travel controller with matching drive motor provide high performance throughout the entire speed range. Travel speed remains constant relative to throttle position regardless of load -neutral braking. Separately fused power control circuits, quick disconnect EPD power cut off, hour meter / battery discharge indicator combination gauge and lift lock-out complete the system.



Power configurations and diagnostic features are displayed with a ZAPI handheld console.

HYDRAULICS

Lift cylinder has hard chrome plated rods. Pump unit including motor, solenoid, gear pump, and pressure compensated lowering valve are mounted high in the power compartment for ease of service.

DRIVE UNIT

Vertically mounted drive motor is direct mounted to gear housing. Oil bathed bevel gear drive train with tapered roller bearings transfers power to axle. State of the art optimized gear technology supplies advantages such as minimal envelope circle, zero maintenance, low noise level, high efficiency and high performance.

Electromagnetic brake is mounted on motor armature shaft multiplying the braking power through the transmission. Brake is applied when control arm is in the vertical or horizontal handle position. System features anti-roll back and neutral braking.

FORK ASSEMBLY

Boxed rail fork construction with pallet entry slide allows easy pallet entry by lifting the fork up and over bottom board.

Eight easily accessed grease zerks for ease of maintenance.

ACCESSIBILITY

Removal of two piece power head cover exposes major components for inspection and maintenance.

OPTIONAL EQUIPMENT

- Cold Conditioning
- Rubber Lug Drive Tire
- Poly Traction Tire
- Fork Entry Rollers
- Load Back Rest - 48"
- Stability Casters
- 8.1" Battery Compartment

Model - WPT45S only available with 27 x 48 fork dimension



OUR METER BDI AND KEY STANDARD

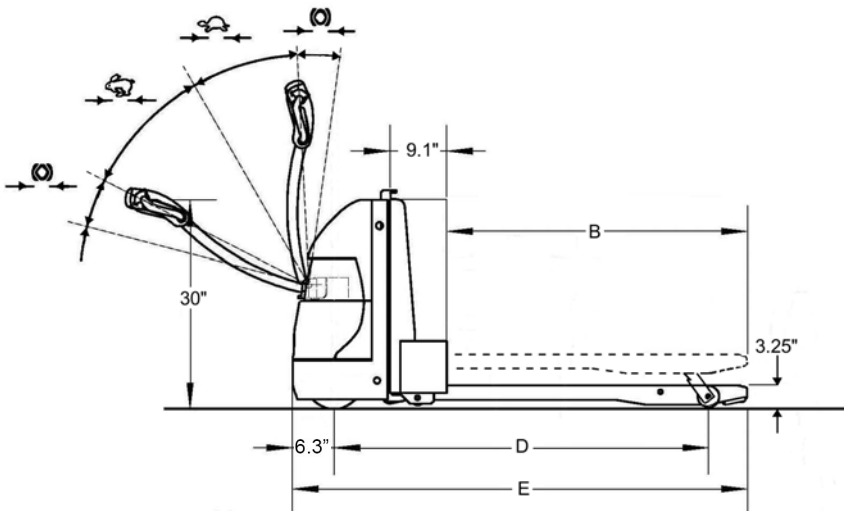
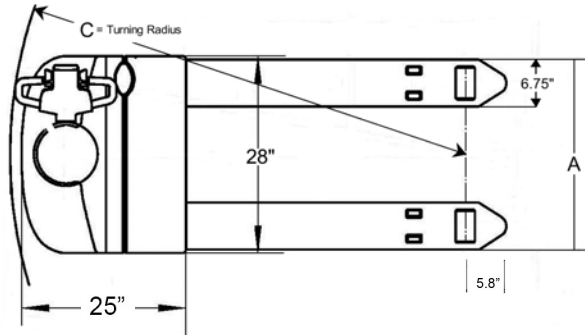

Gradeability	
Without Load	10%
With Load.....	6%
Travel - Variable	
Empty:	0 to 3.5 mph
Loaded:	0 to 3.4 mph
Forks	
Lowered Height:	3.25"
Extended Height:	8.00"
Note: WPT45 22" wide fork units include stability casters as standard equipment	

Truck Model	Forks	Actual Fork Width	Actual Fork Length	Turning Radius	Wheelbase	Overall Length	Weight (lbs.) ³
		A	B	C	D	E	
Fork Dimension: 27" Wide							
WPT 45	27 x 36	27	33.5	54.4	46.4	58.5	875
WPT 45	27 x 48	27	45.5	66.1	58.4	70.5	885
Fork Dimension: 22" Wide							
WPT 45	22 x 36	21.3	33.5	53.8	46.4	58.5	875
WPT 45	22 x 48	21.3	45.5	65.6	58.4	70.5	880

Dimensions listed above are based on 9.1" battery compartment. Stability casters standard on 22" wide models

³ Estimated shipping weight without battery

