



XF Series Diesel / LPG Pneumatic Tire Trucks

with capacities of 8,000 to 11,000lbs

The World of Hangcha



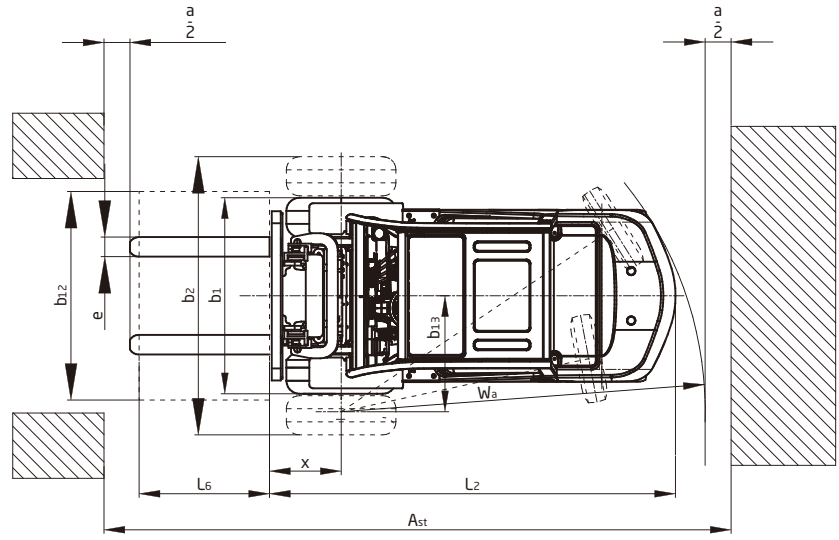
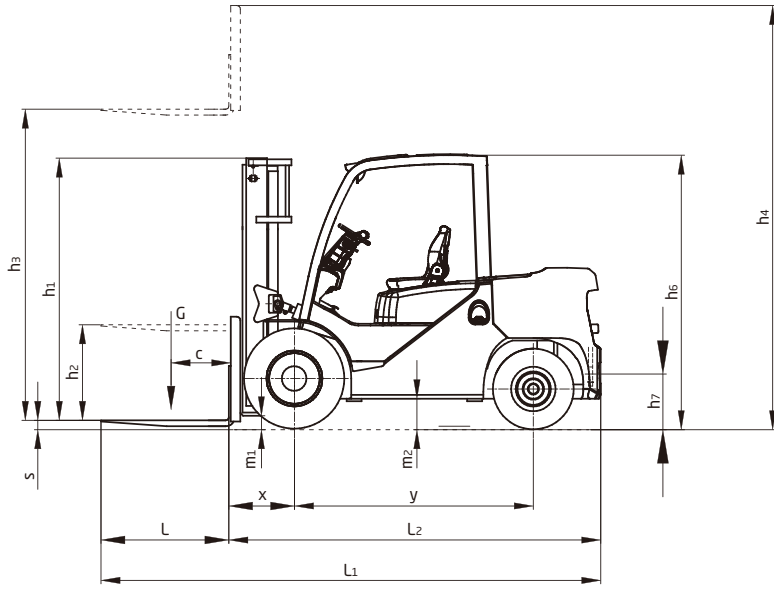

$A_{st} = W_a + x + L_6 + a;$
 applies only if $\frac{b_{12}}{2} \leq b_{13}$

